

2.1 Wiring

2.2 No-Load Brake hoist Wiring

Below is a typical drawing of the Micro-Speed MV™ running a no-load brake hoist with multi speed pendant.

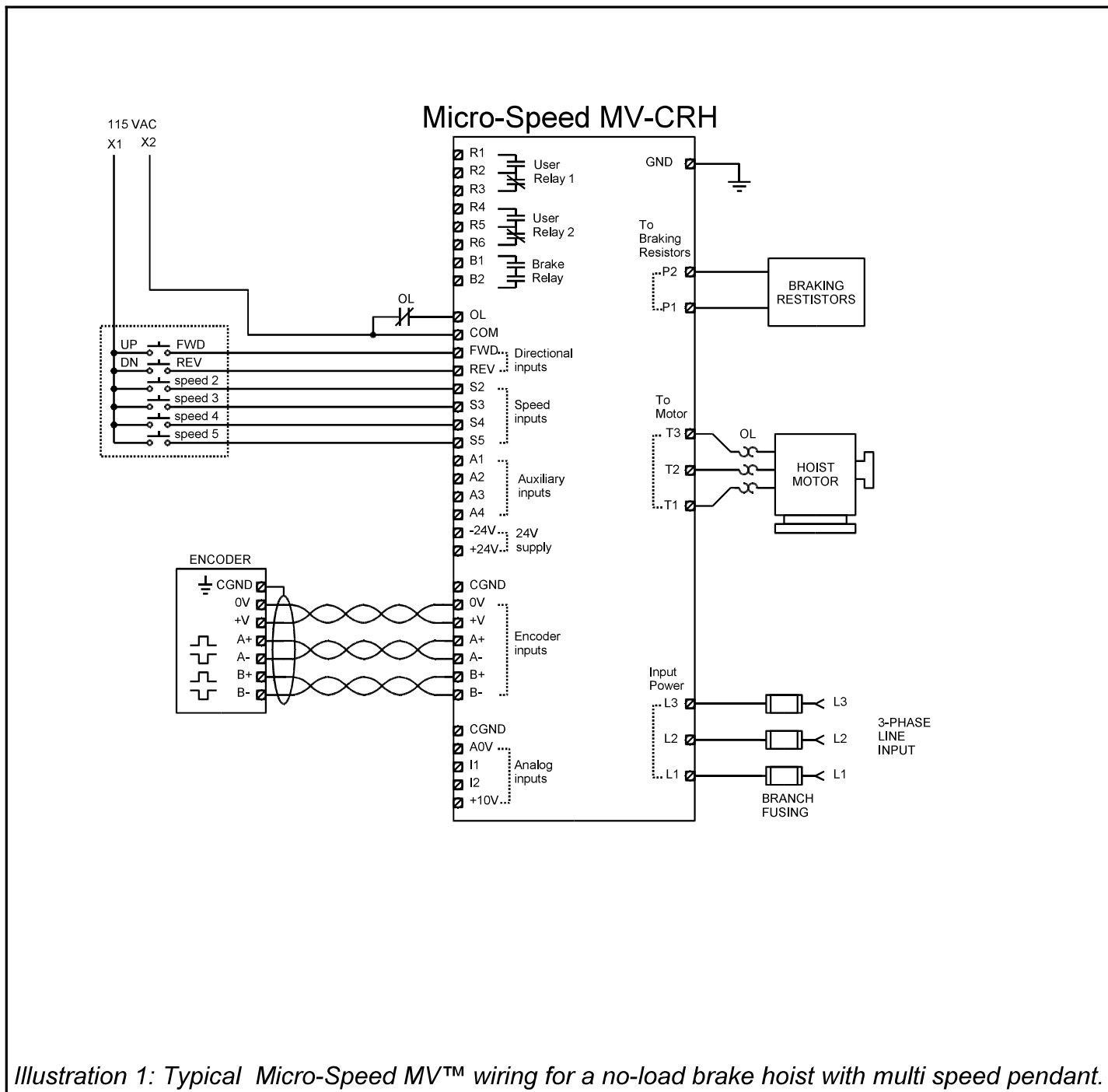

Illustration 1: Typical Micro-Speed MV™ wiring for a no-load brake hoist with multi speed pendant.

2.3 Bridge or Trolley Wiring

A bridge or trolley is wired like the above hoist, except that one brake contactor may be used instead of two.