

## Resistor Hookup Instructions for PE® R3.L.2 Resistor Frames

What resistor models have this frame size?\*

| Resistors that pair with 208-230 VAC VFDs: | Resistors that pair with 380-415 VAC VFDs: | Resistors that pair with 460 VAC VFDs: | Resistors that pair with 575 VAC VFDs: |
|--|--|--|--|
| R5023HL                                    | R5038HL                                    | R5046HL                                | R7557HD, and E                         |
| R6023HF, and L                             | R6038HF, and L                             | R6046HF, and L                         | R10057HD, and E                        |
| R7523HD, E, and F                          | R7538HD, E, and F                          | R7546HD, E, and F                      |  |
| R10023HD, and E                            | R10038HD, and E                            | R10046HD, and E                        |  |
| R10023HL (2X)**                            | R10038HL (2X)**                            | R10046HL (2X)**                        |  |
|  |  | R12546HF, and L (2X)**                 |  |
|  |  | R20046HD (2X)**                        |  |

**Suggestion (prior to Step 1):** Tip the resistor on its side and look underneath to find out which side of the grid has the connection lugs).

1. Remove the **10mm bolts** (circled) from the side cover closest to the wire connection lugs pictured below.
2. Make a knockout hole somewhere on the resistor housing in a location that is convenient for your conduit location (and close to the connection lugs).

**Caution:** DO NOT merely run your wires/leads *under* the resistor frame unless you can ensure the wires will not get pinched underneath the frame.

3. Run your wires/leads through the conduit/knockout hole from Step 2. **Use the same gauge wire as the motor leads you are using for the VFD** (consult the VFD manual).
4. Securely tighten your leads to the wire connection lugs circled in the picture (**13mm bolts**). The lugs may be labeled with P1 and P2 tags.
5. Inspect the resistor frame and resistor elements to **make sure there are loose/foreign objects and that no part of the resistor is contacting the frame or bent (from shipping or otherwise)**. Gently bend any parts or pieces back into place if required.
6. Replace the side cover and bolts back on the resistor.
7. Connect the other end of the resistor leads to the “P1” and “P2” terminals on your VFD (on some VFD models the resistor terminals are labeled “B” and “P”).

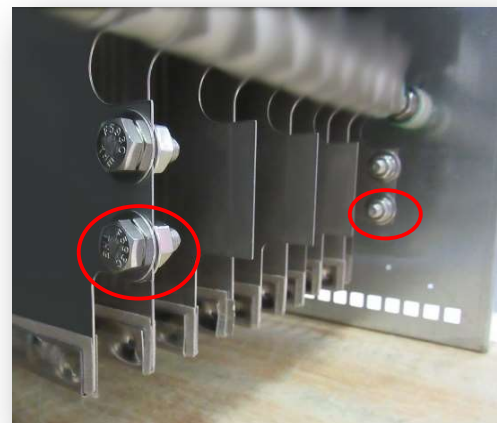
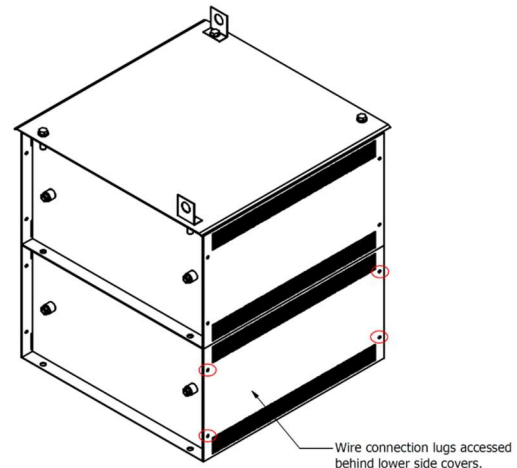

\*Resistor frame sizes, names, and dimensions are subject to change. Additionally, models not listed in the table may use this frame, and some models listed may no longer use this frame size.

\*\*For sizes that require 2X, 3X, etc., connect resistors in parallel.