

2.1 Wiring

Motor rotation direction should be checked after installation.

2.2 General Bridge, Trolley or Hoist Diagram

Below is a typical drawing of the Micro-Speed® CXR with a multi speed pendant.

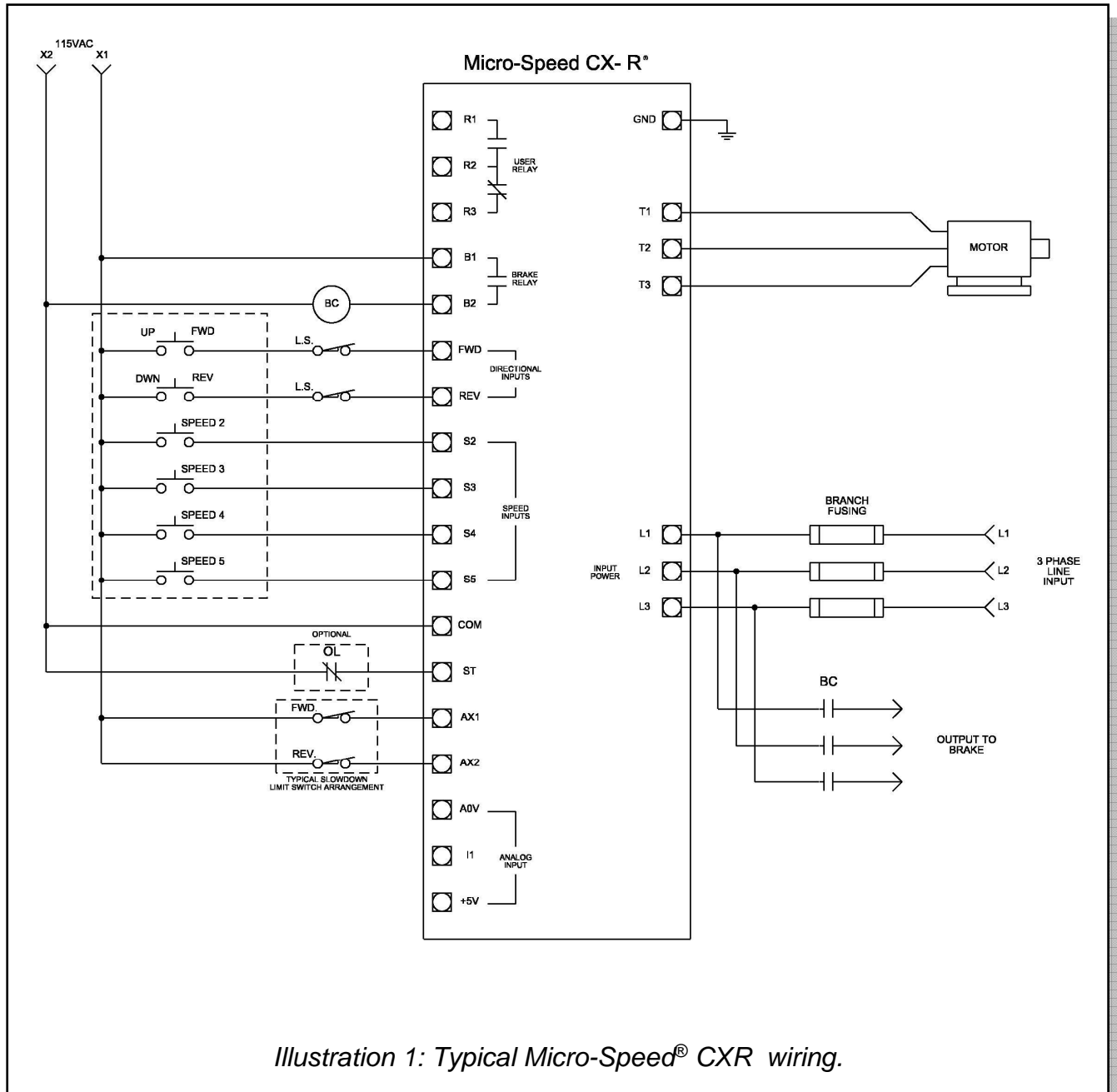

Below is a typical drawing of the Micro-Speed CXRP® with a multi speed pendant.

