

3.1 No-Load-Brake Hoist Wiring

Below is a typical drawing of the Micro-Speed MV-U[®] running a no-load-brake hoist with multi-speed pendant.

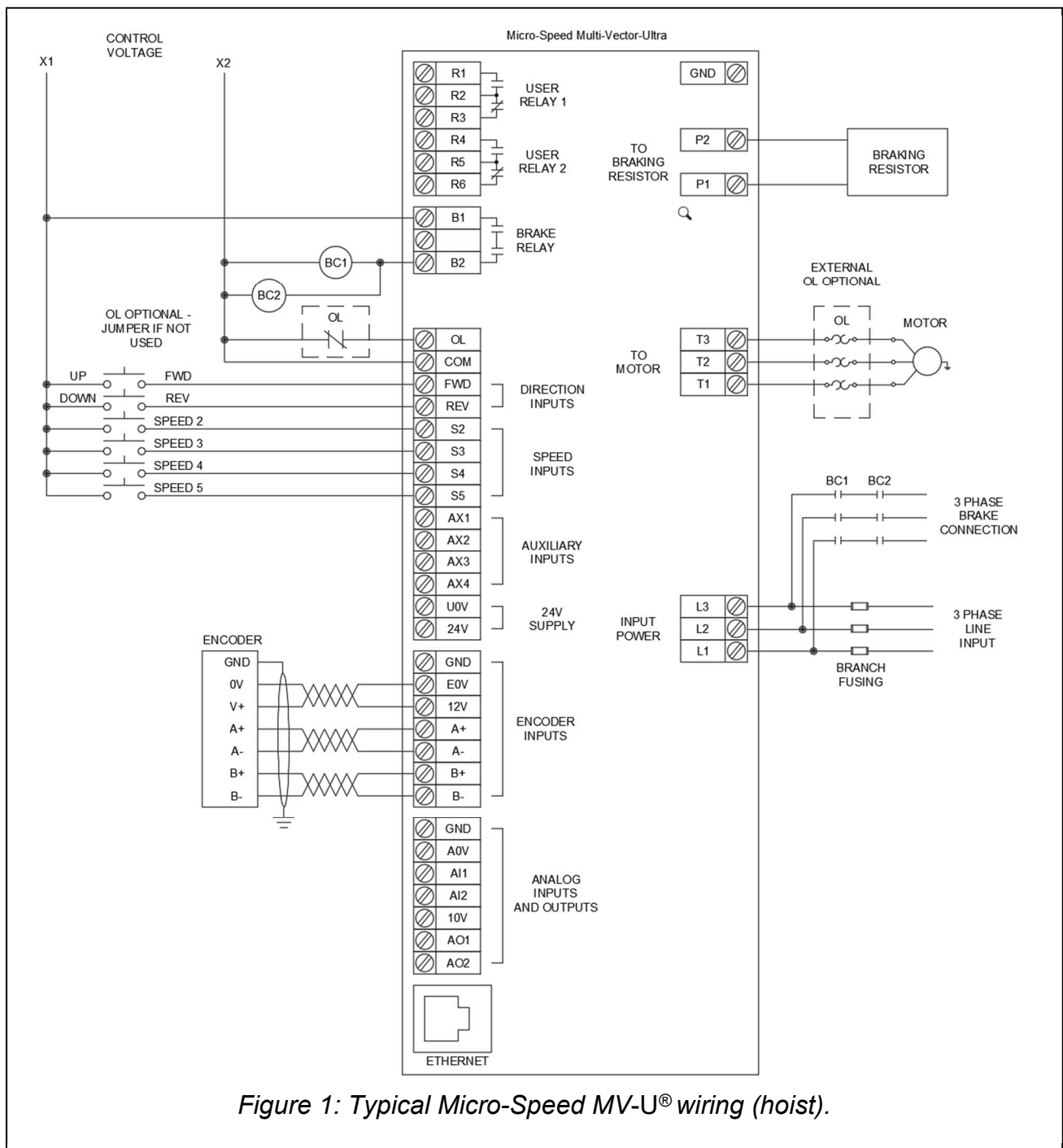

Figure 1: Typical Micro-Speed MV-U[®] wiring (hoist).

3.2 Bridge or Trolley Wiring

A bridge or trolley is wired like the above hoist, except that one brake contactor may be used instead of two. Micro-Speed MX-U[®] units will not have the encoder input terminals as shown in Figure 1.